

MWALL Plus

Foldable All-in-one LED Display



CVTE | QSTECH Co., Ltd.

📍 : No.6, 4th Yunpu Road, Huangpu District, Guangzhou, P.R.China
No.152, Wenxuan 3rd Road, Fengdong New Town, Xi'an, Shaanxi, P.R. China (710086)
🌐 : www.qs-tech.com
✉ : marketing@qs-tech.com



APPEARANCE



Unfolded

Folded

M WALL series products can be widely used in classrooms, conference rooms, multi-functional halls, banks, hotels, shopping malls, entertainment and other places to efficiently delivery contents.

SPECIFICATIONS

Model	QM2712	QM2715
Pixel Pitch (mm)	1.27	1.588
LED Type	SMD 2210	SMD 1212
Display Diagonal (Inches)	110	138
Overall Dimention (mm)	2453×2317×760	3064×2533×780
Display Area (W*H)	2440×1372	3050×1715
Total Weight (kg)	210	265
Resolution (px)	1920×1080	
Brightness (cd/m2)	550	
Refresh Rate (Hz)	3840	
Contrast	6500:1	
Cabinet Material	Magnalium	
Viewing Angle (H/V)	170/170	
Input Port	3- way HDMI2.0 4K@60Hz Signal Input	
Installation Mode	Mobile Stand	
Maintenance	Front	
Power Consumption (Max./Ave.)(KW)	1.31/0.44	1.87/0.64
Input voltage (V)	AC100-240V 50/60Hz	
Operating Temperature/Humidity (C /RH)	-10~40/10~85%	

- Foldable transportation, electric lift, easy installation, plug and play.

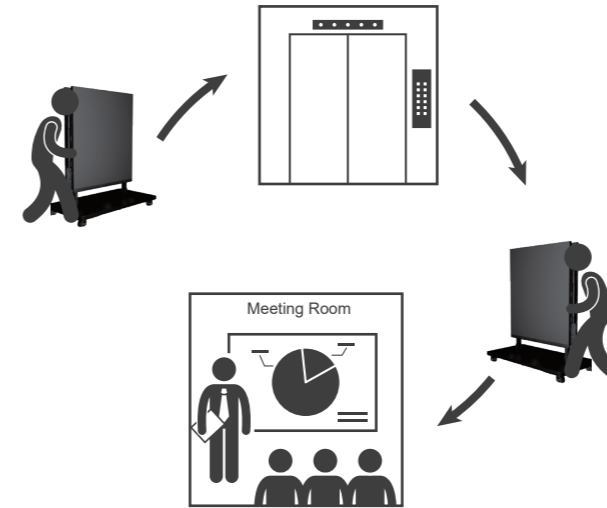

- Initiate three-in-one integrated design of power supply, bridge board and receiving card to reduce electromagnetic interference.

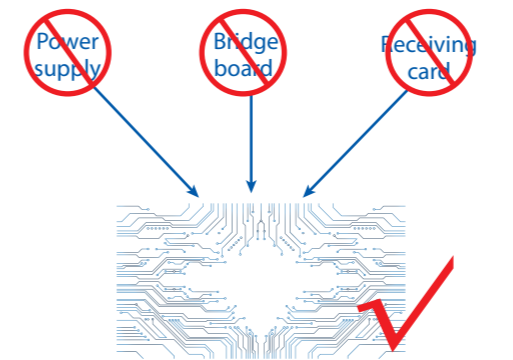

3-in-1 design | 70% improvement on stability | Cable-less simple design & Efficient installation & maintenance

- Remote control with interfaces adapting USB, HDMI and etc.



- All-in-One with slim body and light weight modular design to save your space and make your boardroom brilliant.



- Ultra-large viewing angle plus 8 brightness levels, easy to adjust brightness according to the environments.



- Integrated with external device, wireless screen transmission via PC, mobile phone and tablet, instant interaction at any moment.

